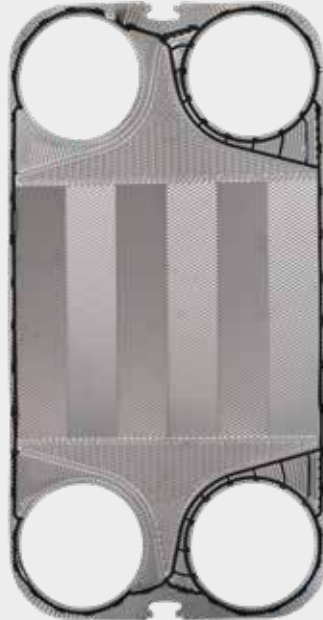

Plate Heat Exchanger SF500 Series

SF502 & SF503



SonFlow offers a wide range of Plate Heat Exchangers and is the ideal choice suitable for a wide variety of applications across numerous markets segments. SonFlow Plate Heat Exchanger SF500 series will cover many duties in a single pass solution.

Typical applications:

- Heat recovery
- HVAC
- Geothermal
- Industrial
- Marine
- Chemicals
- Sugar industry
- Mining
- Electronics

- Lock gasket system
- Gentle product handling
- Design pressure up to 16 bar
- Operating temperature: up to 180° C
- Leak chamber
- Fixed bolt head
- Lifting lug
- Lining
- Lock washer

Features:

Every detail is carefully designed to ensure optimal performance, reduced maintenance costs and decreased downtime:

- Compact design
- High flexibility

Benefits:

- Lower operating costs
- Cost-effective
- Easy assembly
- Increased energy efficiency
- Easy cleaning
- Dead spots, that cause corrosion and fouling are eliminated

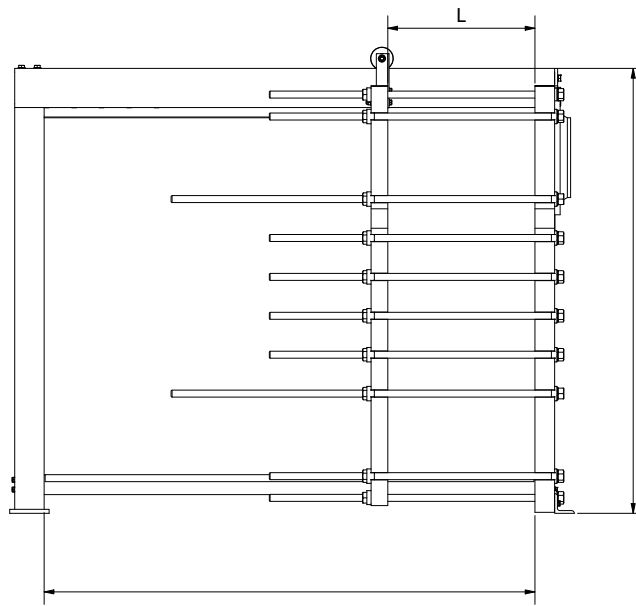
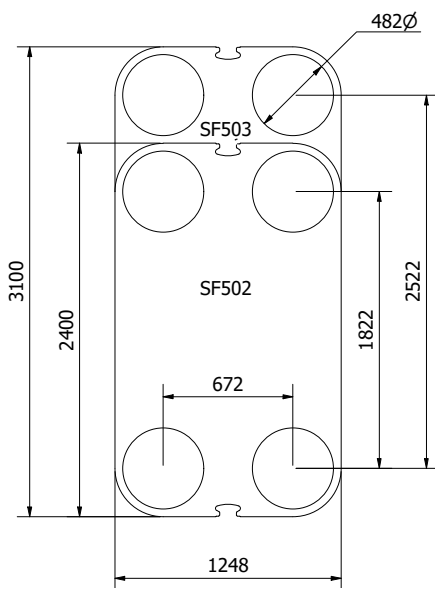

Dimensions in mm

Design pressure:

- Painted frames: 1.0/1.6 MPa (145/232 PSI)

Construction standards:

- EN13445
- ASME sec VIII, Div. 1

Frame:

- Painted frame, RAL 5010 (available in other colours)

Connections:

- DN 500/20" flange in carbon steel, rubber lined or clad with AISI 316 or titanium
- According to all known standards

Plate material:

- AISI 304/316 and titanium
- Other materials available on request

Gaskets:

- Click on gasket – a glue less system for sealing
- Materials: NBR, EPDM and Viton
- Other materials available on request

Accessories:

- Drip tray
- Insulation jackets
- Safety cover
- Assembling spanner
- Foundation feet