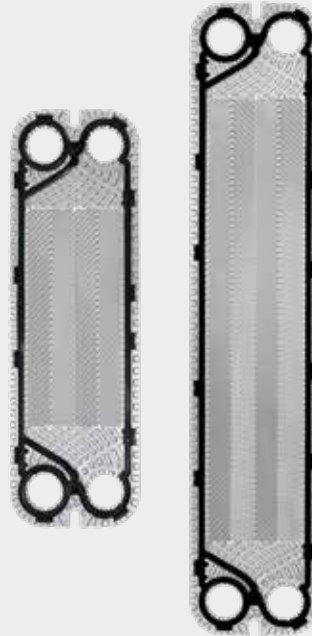

Plate Heat Exchanger AF30 Series

AF31 & AF33



SonFlow



SonFlow offers a wide range of AHRI-certified® products, including the AF30 series. The series is certified in the category of "AHRI Liquid to Liquid Heat Exchangers," which confirms the thermal performance according to the specified specifications. With the AF30 series, SonFlow offers a reliable and efficient single-pass solution that is suitable for many different applications. This is a cost-effective solution that ensures optimal heat transfer and minimal maintenance.

Typical applications:

- HVAC-R
- Heat recovery
- General industry
- Food & beverage
- Sugar industry
- Chemical industry
- Marine
- Mining
- Electronics

- Gentle product handling
- Design pressure up to 25 bar
- Operating temperature: up to 180° C
- Leak chamber
- Fixed bolt head
- Lifting lug
- Lining
- Lock washer

Features:

Every detail is carefully designed to ensure optimal performance, reduced maintenance costs and decreased downtime:

- Compact design
- High flexibility

Benefits:

- Lower operating costs
- Cost-effective
- Easy assembly
- Increased energy efficiency
- Easy cleaning
- Dead spots, that cause corrosion and fouling are eliminated



SonFlow

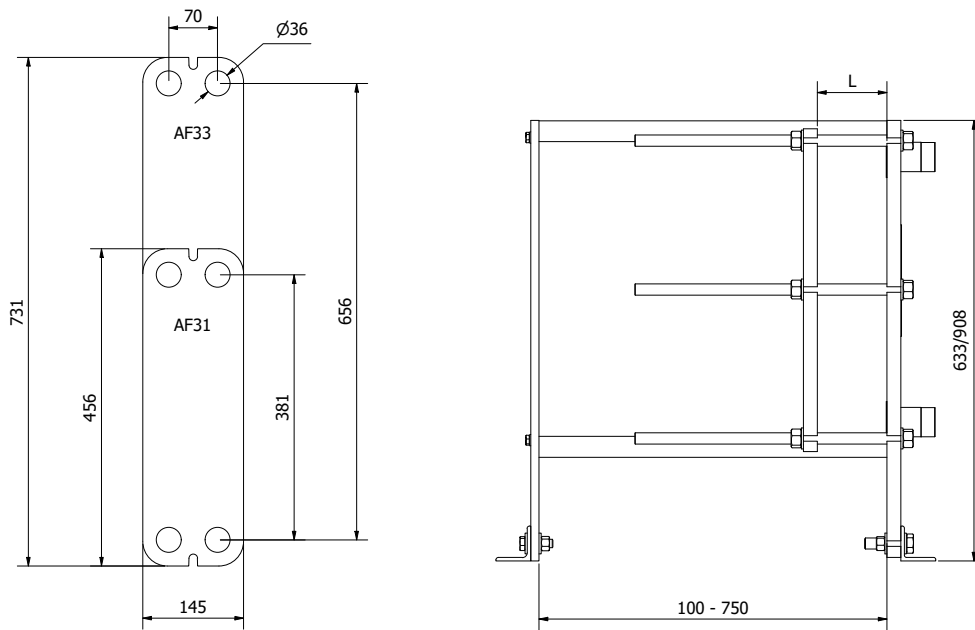

Dimensions in mm

Design pressure:

- Painted frames: 1.0/1.6/2.5 MPa (145/232/362 PSI)
- Stainless steel: 1.0/1.6 MPa (145/232 PSI)

Construction standards:

- EN13445
- ASME sec VIII, Div. 1

Frame:

- Painted frame, RAL 5010 (available in other colours)
- Stainless steel frame

Connections:

- DN 25/1" dairy pipe or union
- 1¼" threaded pipe BSP/NPT, stainless steel or titanium
- 1.5" threaded pipe BSP/NPT, stainless steel or titanium
- According to all known standards

Plate material:

- AISI 304/316 and titanium
- Other materials available on request

Gaskets:

- Hang-on gasket
- Materials: NBR, EPDM and Viton
- Other materials available on request

Accessories:

- Drip tray
- Insulation jackets
- Safety cover
- Assembling spanner
- Foundation feet



AHRI Certified® is the trusted mark of performance for heating, air conditioning, water heating, and commercial refrigeration equipment. To find AHRI Certified products, go to www.ahridirectory.org.

Certificerede products in the AF30 Series

Model number	AHRI Certified Reference Number
AF31PS16	214472366
AF31PL16	214472367
AF33PS16	214472368
AF33PL16	214472369